

Maxwell Thomas®

By Direct Supply

Oak Park Occasional Table Collection

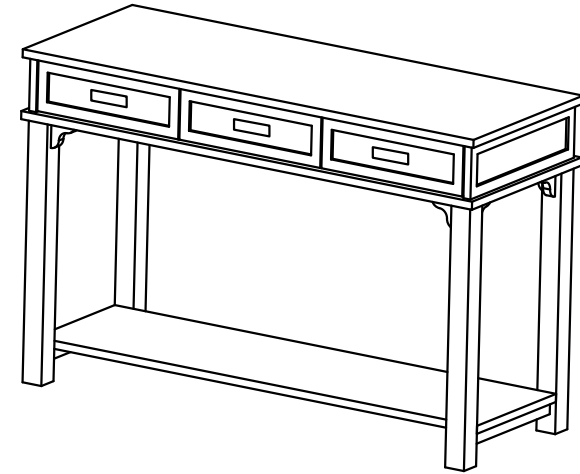
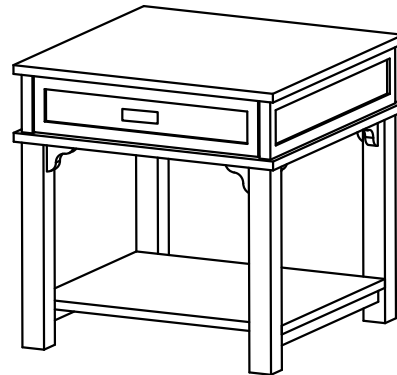
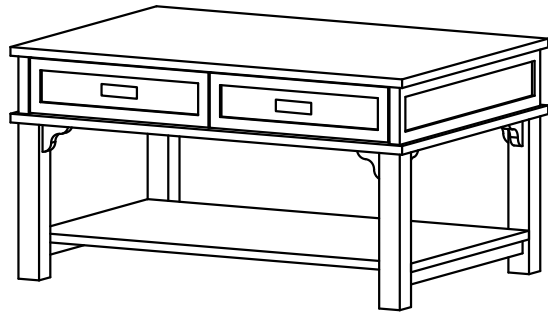

| Dimensions: | Top Surface Weight Capacity* | Shelf Weight Capacity* | Overall Height | Overall Width | Overall Depth | Shelf Height | Leg Clearance Height | Unit Weight |
|-----------------------|------------------------------|------------------------|----------------|---------------|---------------|--------------|----------------------|-------------|
| Oak Park Coffee Table | 300 lbs. | 40 lbs. | 20" | 38" | 26" | 5¾" | 26" | 88 lbs. |
| Oak Park End Table | 150 lbs. | 40 lbs. | 24" | 24" | 18" | 5¾" | 24" | 66 lbs. |
| Oak Park Sofa Table | 200 lbs. | 40 lbs. | 31" | 48" | 24" | 5¾" | 18" | 118 lbs. |

Construction:

Top-quality oak veneer and oak hardwood. Dowel, screws, camlocks and bolt construction for a super-durable, commercial-grade occasional table.

Floor Glides:

Adhesive-backed felt pads.

Drawers:

½" European beech plywood drawer boxes with finger joints and screws. 75 lb. ball-bearing drawer slides.

Warranty:

7-year limited warranty.

Tops:

Finish-matched high-pressure laminate (HPL) with oak hardwood trim.

Customization:

Customization is possible – please contact your Direct Supply account manager to learn more.

Certifications:

CARB II and BIFMA 5.5X certified.

Hardware:



basketweave pull

Finishes:

All veneer and hardwood surfaces are finished in a commercial-grade catalyzed lacquer finish.



Also Available in Oak Park:

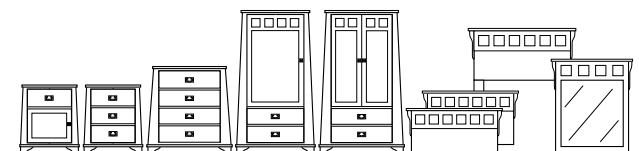

Oak Park Veneer Casegoods

* **WARNING:** Do not sit or stand on the occasional table top or lower shelf. Doing so could cause bodily harm to the resident and/or caregiver.