

User/Service Manual  
Joerns® Assist Device

Model F025

To avoid injury, read user's manual before using bed.

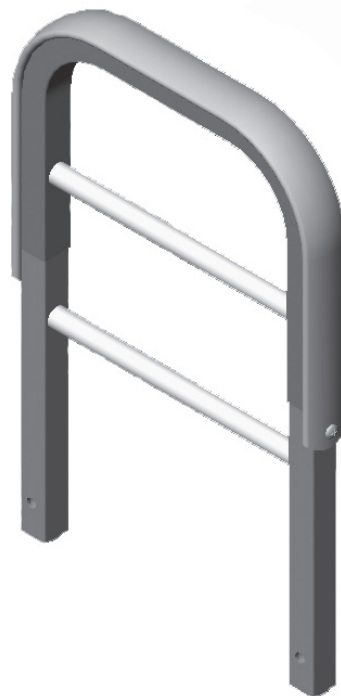

## Important Precautions

- ⚠ Warning: Possible Injury Or Death.** This product is intended for use with Joerns bed models B784, B694, B684, B684DC, B624, B675, B530, B330, B40, B40E, B41, and B41E. Use of this product on any bed it was not designed for could result in an unproven or unsafe configuration, potentially resulting in serious injury or death. For questions regarding compatibility, contact your Joerns representative.
- ⚠ Warning: Possible Injury or Death.** Use a properly sized mattress in order to minimize the gap between the side of the mattress and the assist device. This gap must be small enough to prevent a resident from getting his/her head or neck caught in this location. Make sure that raising or lowering the bed, or articulating the sleep surface does not create hazardous gaps. Failure to do so could result in serious injury or death.
- ⚠ Warning: Possible Injury or Death.** Properly locate the mounting brackets for the assist device. The gap between the head/foot board and the assist device must be large enough to prevent a resident from getting his/her head or neck caught in this location (see the installation instructions for more information). If multiple assist devices are needed, position them such that the gap between them is large enough for the trunk and hips to easily pass through. Make sure that raising or lowering the bed, or articulating the sleep surface does not create hazardous gaps. Failure to do so could result in serious injury or death.
- ⚠ Warning: Possible Injury or Death.** Do not use this assist device if any openings within the assist device body will allow a resident to get his or her head or neck lodged within these openings. Failure to do so could result in serious injury or death.

Joerns® assist devices or side rails are designed to be used with specific Joerns bed frames. Once mounted on the appropriate bed frame, assist devices or side rails become an integral part of the Joerns bed system. As such, these mounted assist devices or side rails can handle the same safe working load, within normal use conditions, of the appropriate bed to which they are mounted.

When assessing the risk for entrapment, you need to consider your bed, mattress, head/foot boards, assist devices and other accessories, as a system. It is also extremely important to review the resident/patient's physical and mental condition and initiate an appropriate individual care plan to address entrapment risk. All Joerns bed systems are evaluated for compliance to the FDA/CDRH "Hospital Bed System Dimensional and Assessment Guidance to Reduce Entrapment."

Assemble, install, utilize and maintain Joerns Side Rails/Assist Devices as described in their accompanying Joerns User/ Service Manual, which also lists the bed type or model with which these devices may be used.

This product is only one part of your healthcare bed system. Proper combinations of mattress, head/foot boards and assist devices are needed to minimize the risk of entrapment. For more information, call Customer Care, 800-826-0270.

### Save These Instructions

Thank you and congratulations for choosing Joerns Assist Devices. Joerns assist devices are developed with safety, comfort and convenience of both residents/patients and caregivers in mind.

Advanced ergonomic design will provide years of reliable service in your facility.



## Table of Contents

Important Precautions .....2  
 Entrapment Information .....4  
 Specifications .....5  
 Assembly .....6  
 Operation .....7  
 Cleaning .....7  
 Maintenance .....7  
 Warranty .....8

### Bed System Entrapment Information

Although essential in the practice of long-term care, bedside rails, in recent years, have also been a subject of regulatory review and evolution in design and use.

That focus includes not only the challenge of achieving an appropriate balance between resident security and unnecessary restraint, but also the additional safety issue of entrapment.

The U.S. Food and Drug Administration (FDA), working with our company and other industry representatives has addressed the potential danger of entrapment with new safety guidelines for medical beds. These guidelines recommend dimensional limits for critical gaps and spaces between bed system components.

Entrapment zones involve the relationship of components often directly assembled by the healthcare facility rather than the manufacturer. Therefore, compliance is the responsibility of the facility.

As the leading manufacturer of long-term care beds and a frontrunner in addressing this critical issue, Joerns Healthcare can offer you the expertise, assistance and products to bring your facility into compliance.

### Joerns® Compliance Solutions

Matching the right bed components in order to meet regulatory guidelines can be complex.

That's why Joerns offers a wide array of compliance options. We assist customers in selecting compliant accessories recommended for their specific bed model.

### Creating a Safer Care Environment

While the guidelines apply to all healthcare settings (hospitals, nursing homes and at home) long-term care facilities have particular exposure since serious entrapment events typically involve frail, elderly or dementia patients.

### For More Information

To learn more about compliance options with Joerns products, visit our website at [www.joerns.com](http://www.joerns.com), or contact our Customer Care reps (800-826-0270) and ask for free informational publications.

To learn more about entrapment zones, assessment methods, and guidelines concerning entrapment, contact Joerns Healthcare (800-826-0270) or consult the FDA website: [www.fda.gov/cdrh/beds](http://www.fda.gov/cdrh/beds)



## Assembly

For Joerns® Bed Models: B784, B694, B684, B684DC, B624, B675, B 530, B330, B40, B40E, B41, B41E

*Suggested Tools: 7/16" Deep Well Socket with ratchet, 1/2" Socket Wrench, 3/8" Torque Wrench*

### Parts List

| Item # | Description   |
|--------|---|
| 1..... | 1 - Assist Handle                                   |
| 2..... | 2 - Carriage Bolts (5/16" x 2.5")<br>(PN: 12523760) |
| 3..... | 2 - Spacer Tubes (PN: 11012033)                     |
| 4..... | 2 - Lock Nuts (5/16" - 18 Hex)<br>(PN: 12673104)    |
| 5..... | 2 - Flat Washers (PN: (12843788)                    |

1. Install the mounting bracket (not included) as far to the center of the bed as possible. This requires removing the bolts (item A) for the mounting brackets, moving the brackets to the required location, and re-installing the bolts (Figure 1). Tighten to 9 lbs-ft.
2. Place bushings (item 3) in the large mounting bracket holes (Figure 3).
3. Place bolts (item 2) through holes in assist handle (item 1) (Figure 3).
4. Put bolts through the bushings (item 3). Place washer (item 5) over the bolt (item 2) and thread nut (item 4) on the bolt (item 2) and tighten to 17 lbs-ft (Figure 3).

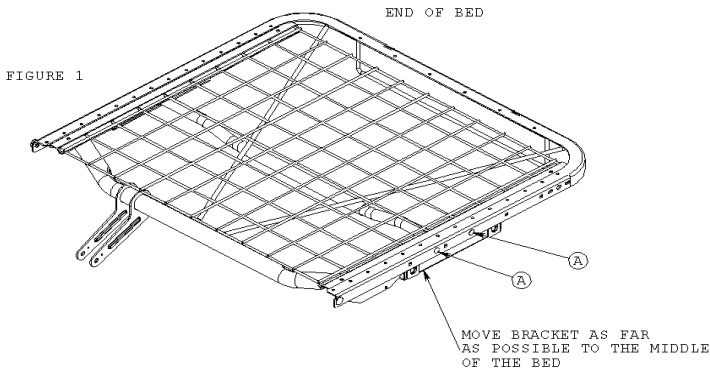

FIGURE 1

## Maintenance/Inspection Information

Visually inspect the assist device and mounting bracket as well as check for loose hardware on a monthly basis. Tighten as stated in the assembly instructions.

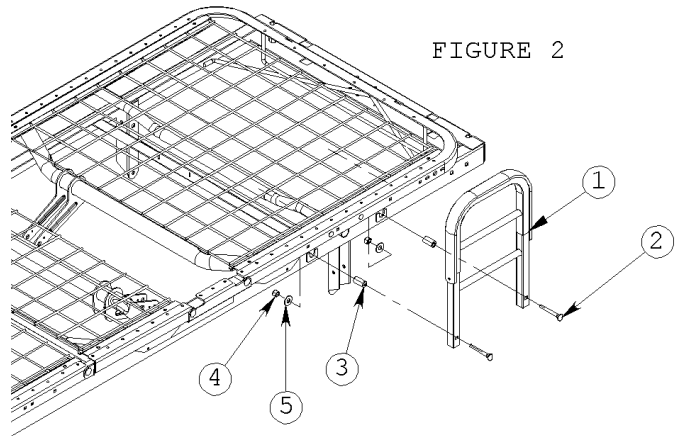

FIGURE 2

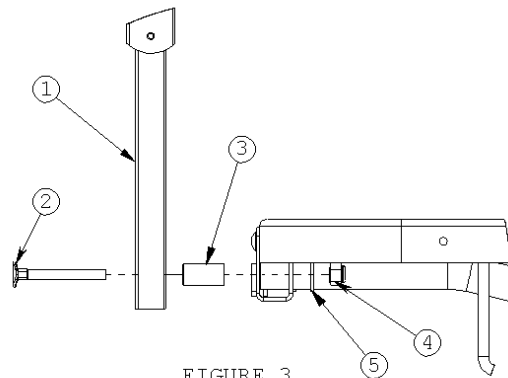

FIGURE 3  
EXPLODED VIEW FROM END OF BED

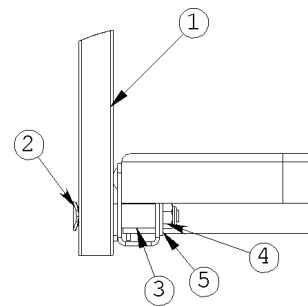

FIGURE 4  
COLLAPSED VIEW FROM THE END OF BED



Notes:





# Joerns® Assist Device

F025 Model

Notes:





Notes:





## Joerns Healthcare Warranty Program

for all Joerns® assist devices and side rails

Joerns assist devices and side rails are guaranteed for a period of 12 months from the date of delivery against defects in materials and workmanship under normal use and service.

Steel structural components and welds are covered under warranty for a period of ten years from the date of delivery.

This warranty does not apply to damage or defects caused by misuse, incorrect handling, or installation by a non-authorized installer. Damage caused by use in unsuitable environmental conditions or failure to maintain the product in accordance with user and service instructions is not covered. Any alteration, modification or repair unless performed by or authorized in writing by Joerns Healthcare will void this warranty.

The product contains various parts that wear from normal use. These parts, such as plastic bushings, are not covered under the 12-month warranty, but are covered for 90 days after purchase of product.

Joerns Healthcare's obligation under this warranty is limited to supplying replacement parts, servicing or replacing, as its option, any product which is found by Joerns Healthcare to be defective.

Warranty replacement parts are covered by the terms of this warranty until the product's original warranty period expires.

When requested by Joerns Healthcare, parts must be returned for inspection at the customer's expense. Credit will be issued only after inspection. Healthcare to be defective.

## Service

Most service requests can be handled by the facility Maintenance Department with assistance from the Joerns Healthcare Product Service Department.

Most parts requested can be shipped next day air at the customer's expense.

Should a technician be required, one will be provided by Joerns Healthcare, at our discretion. Only the Joerns Healthcare Product Service Department can dispatch authorized technicians.

This warranty is extended to the original purchaser of the equipment.

